

**KOBELCO**

SK35SR-6

# **MINI EXCAVATOR SK35SR**



**DRIVEN BY  
PASSION**

# Full-Size Performance, Short-Radius Agility and Quiet Operation

## **COMPACT YET TOUGH MINI**

The new KOBELCO SK35SR expand the horizons of mini excavators, and offers practical performance features while maintaining a short tail swing. The new Energy Conservation Mode saves even more fuel, and Kobelco's proprietary iNDr Cooling System ensures quiet operation, protection from dust, and easy maintenance. For greater operator comfort and safety, the spacious cab design offers plenty of room and an unobstructed view. It all adds up to enhanced full-size performance, short-radius agility and a low-noise environment, with exceptional performance features and a full range of value-added functions.

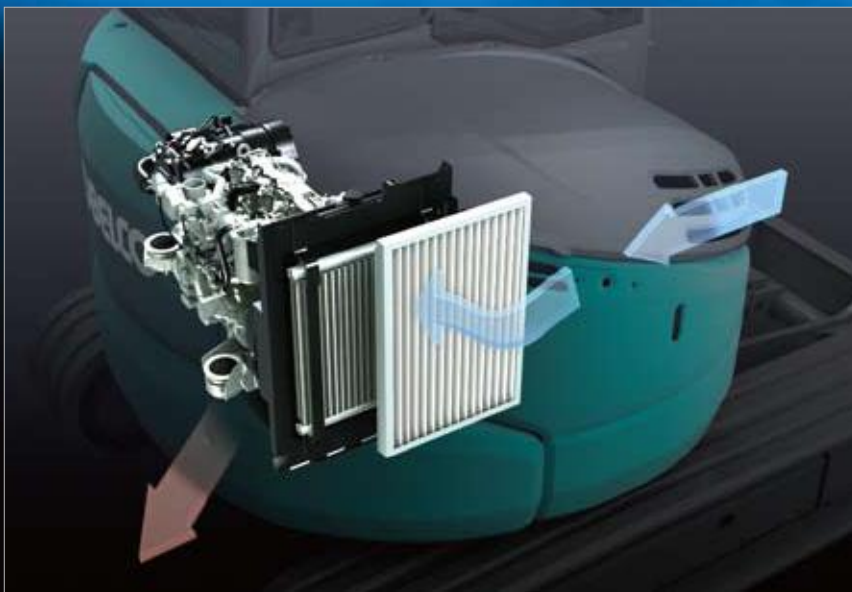



# iNDr Cooling System

## The Revolutionary Integrated Noise and Dust Reduction Cooling System



The highly airtight engine compartment and the offset duct contribute to noise reduction. The iNDr filter fitted in front of the cooling system ensures easy cleaning. The iNDr system on the SR Series mini excavators features air intake at the front of the machine and air exhaust underneath. It functions in the same way as the iNDr System on the SR series machines.

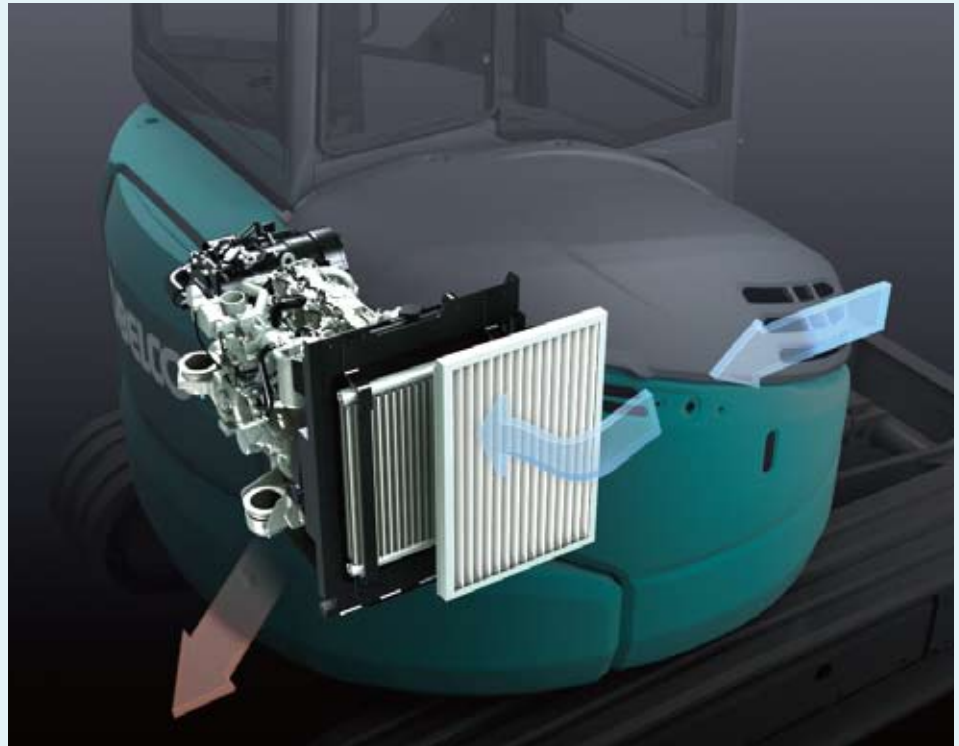

### Visual Checking and Easy Cleaning

Because the iNDr filter removes dust from the intake air, cooling components stay dirt-free and do not require regular cleaning. The iNDr filter itself can be easily removed and cleaned without the use of tools.



### iNDr Filter

The stainless-steel filter is extremely effective against dust, with 30-mesh wave-type screen that removes tiny dust particles from the intake air.

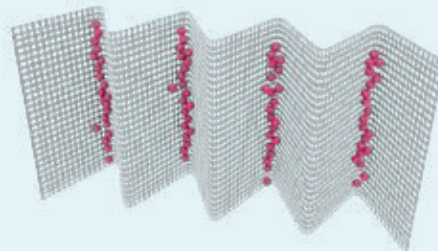

•30-mesh means that there are 30 holes formed by horizontal and vertical wires in every square inch of filter.

### iNDr Filter Blocks Out Dust

Outside air goes directly from the intake duct through the iNDr filter for dust removal.



### Ultimate Low Noise

KOBELCO's exclusive iNDr Cooling System delivers amazingly quiet operation.

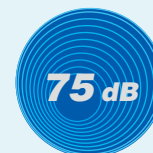

at 1 m backward from machine rear end and 1.5 m height from ground level.

## PERFORMANCE

# Compact, yet, Big Performance

### Wide Working Range

A larger boom and arm are provided as standard equipment to ensure a wider working range.

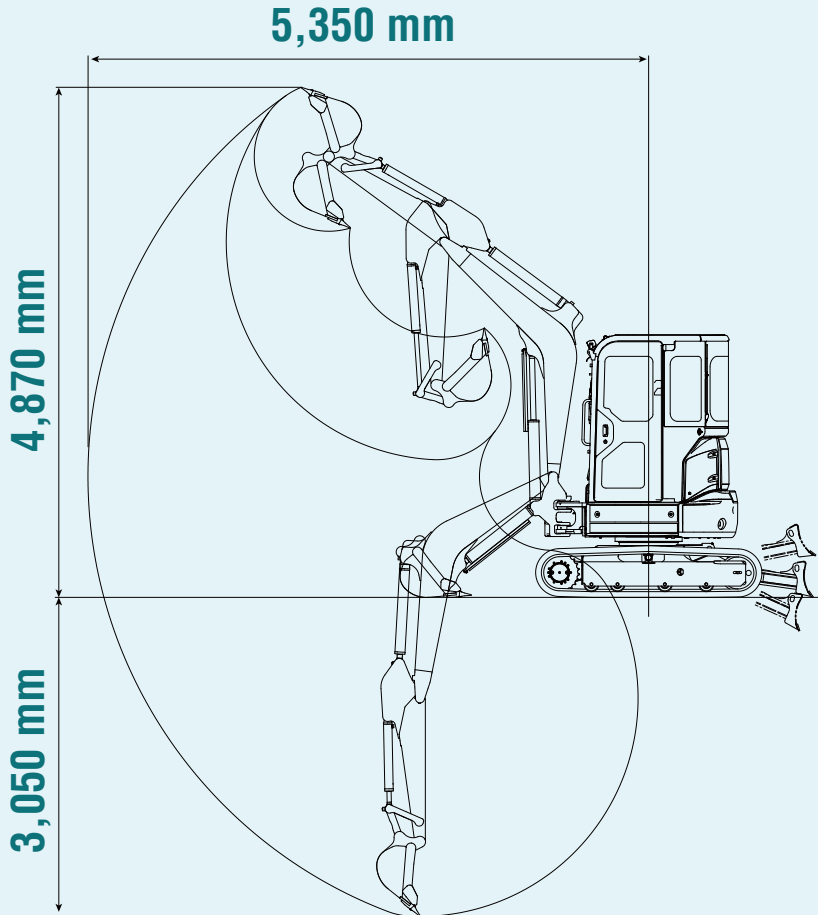

### Short Tail Swing

The compact tail swing improves operating efficiency in limited space.

Tail overhang:  
0 mm

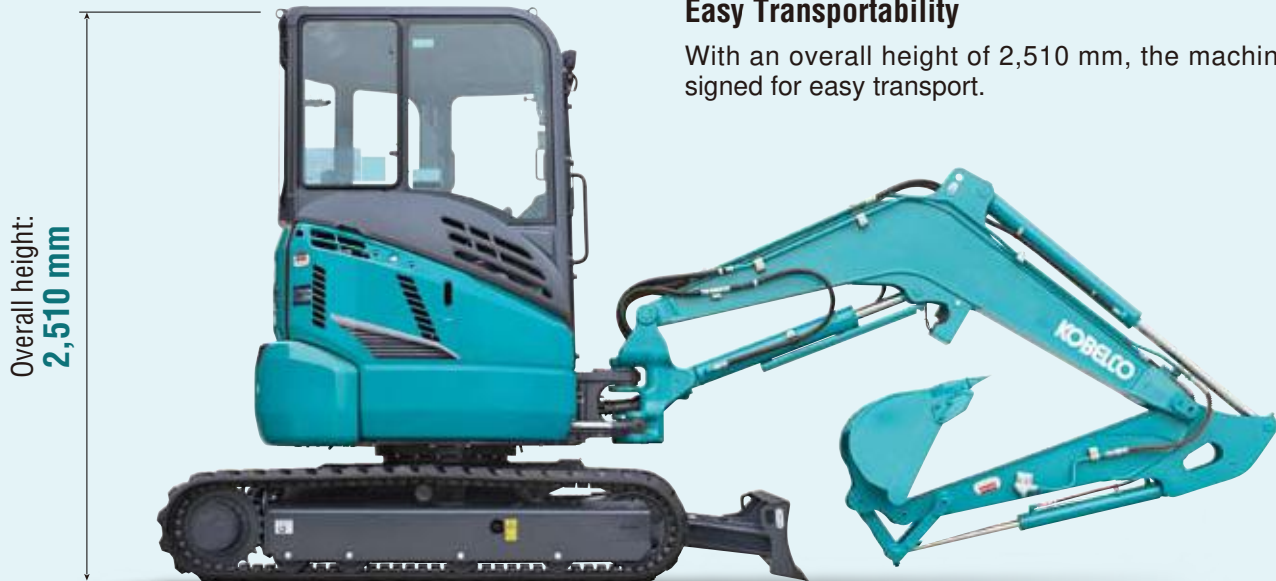

### Easy Transportability

With an overall height of 2,510 mm, the machine is designed for easy transport.

# Fuel Economy and Digging Power

## Solid Digging Performance

### Assured Pump Flow and Pump Pressure

Pump flow of 38.4 L/min for and pressure of 23.0 MPa (relief valve setting), maintain ample power.

### Integrated-Flow Pump System

The instant the machine begins to dig, extra output from the third pump (which otherwise powers the swing and dozer circuit) is directed to the arm circuit and boom circuit (raise) for added power. This ensures fast and smooth arm and boom raising operation even under heavy loads.

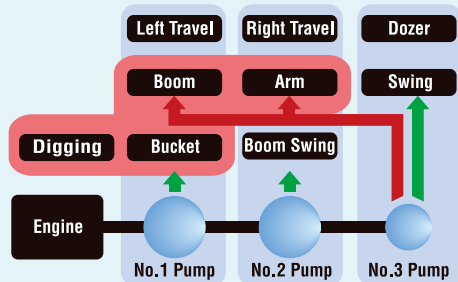

### Energy Conservation Mode

SK35SR equipped with S mode, which lowers fuel consumption by up to 25 % over previous models.



### One Touch Deceleration

The machine features one-touch deceleration. It allows easy switching to an idling state, reducing the fuel consumption while the machine is at rest.



## Travel Power

### Large Capacity Travel Torque

The large capacity travel torque enables the machine to perform spin turn in low mode even when the dozer is pushing a heavy load.

### Automatic Two-Speed Travel

An automatic shift function ensures smoother, more efficient travel on worksite. When the High mode is selected, the travel system will automatically shift to Low mode whenever the load or climbing grades requires more power.

### Travel Switch

The travel lever is fitted with a button for easy switching to H-Mode travel.



## Powerful and Efficient Dozer Performance

### Dozer-Blade Shape

KOBELCO's unique blade design solves this problem by forming the earth into an arc that always falls forward. Because this prevents earth from falling behind the blade, only "one pass" is needed. (Patent pending)



### Hydraulic Pilot-Controlled Dozer Operation Lever



The dozer lever features hydraulic pilot control for precise handling.



## MAINTENANCE

# Easy Daily Maintenance

Start-up checks are essential for safe and reliable machine operation. All start-up checks can be performed at ground level, with an easy-to-understand layout and cover design that simplify access and save time.

### Easy Access to Component Under the Seat



Two-piece floor mats for easy washing



Hour meter



### Easy Access to Engine Compartment



High-grade fuel filter



Pre fuel filter with built-in water separator



Air cleaner

### Easy Access to Cooling Unit

iNDR filter



Fuel tank

COMFORT

## Comfortable Work Environment



### Spacious Work Environment

The newly designed, rectangular cab is over 820 mm wide, with optimized control layout for comfortable, easy operation. A greater window area further improves visibility. A clear view is provided at the rear, and there's also more floor space, with a seat that slides further to ensure plenty of leg room.

### Easy Access

A wide-opening door and a left-hand tilting control console with safety lever that rises high, make it easy for operators to enter and exit the cab.



### Skylight



### Control Lever

Precise proportional controls are integrated into the joystick for ease of operation.



### Work Light



Working light is mounted under the boom to protect from damage.

# Comfortable Operating Environment

## Hammer for emergency exit



## Climate control

The climate control system is located down and to the right of the seat, keeping the rear view clear.



Vents to send cooled air toward the operator if he desires.



## Opening/closing front window

The front window features gas damper cylinders for smooth and easy opening and closing.



## Coat hook



## Room light



## Two-speaker FM/AM radio with station select



# Operator Safety

## Reliable Cab Structure

The high-strength cab meets ROPS and TOPS GUARD LEVEL 1 standards for greater operator safety.



## RELIABILITY

# Reliable Construction

The boom, arm and swing bracket all have large cross-section segments for added attachment strength.

### Strong boom and arm

Bolt-tightened pins firmly lock the boom and arm to prevent the boom top from opening laterally.



Forged boom top



Plate type pin

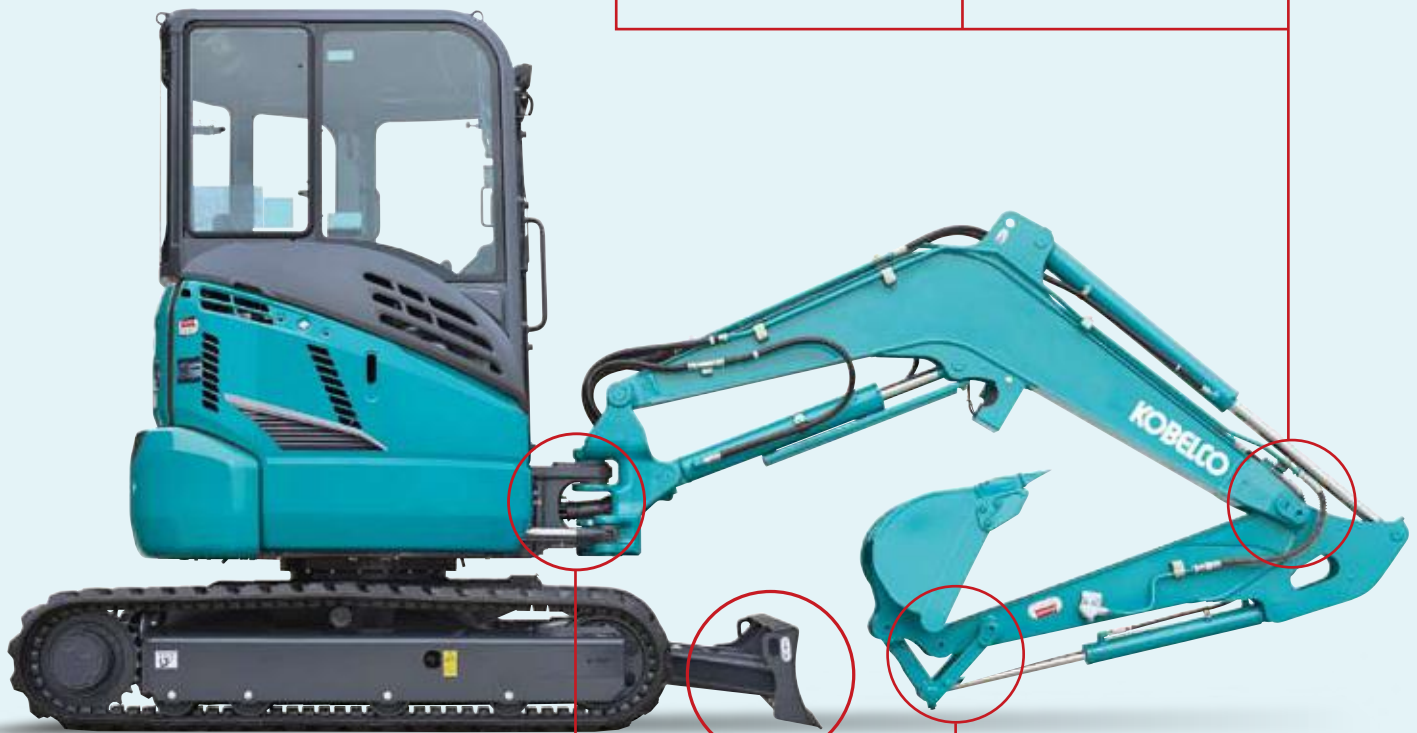

### Swing bracket

Large, thick cast-iron swing bracket/front bracket.



### Hydraulic piping

The hydraulic piping is housed inside the swing bracket.



### Dozer

Box construction dozer supports provide greater strength.



### Bucket

Cast-iron idler link provide greater strength.

## SPECIFICATIONS

MODEL		SK35SR	
Type		SK35SR-6	
Machine Mass	kg	3,770	
Bucket Capacity	m <sup>3</sup>	0.11	
Bucket Width (with side cutter)	mm	600	
Arm Length	m	1.37	
Bucket Digging Force	kN	27.8	
Arm Digging Force	kN	22.4	
<b>ENGINE</b>			
Model		YANMAR 3TNV82A-B	
Type		Water cooled, 4-cycle, 3-cylinder, direct injection, diesel engine	
Power Output	(ISO 9249) kW/min <sup>-1</sup>	17.1/2,400	
	(ISO 14396) kW/min <sup>-1</sup>	18.1/2,400	
Max. Torque	(ISO 9249) N-m/min <sup>-1</sup>	77.7/1,440	
	(ISO 14396) N-m/min <sup>-1</sup>	79.4/1,440	
Displacement	L	1.331	
Fuel Tank	L	42	
<b>HYDRAULIC SYSTEM</b>			
Pump		Two variable displacement pumps + One gear pump	
Max. Discharge Flow	L/min	2 x 38.4, 1 x 19.2	
Relief Valve Setting	MPa	23.0	
Hydraulic Oil Tank (system)	L	20.4 (44.8)	
<b>TRAVEL SYSTEM</b>			
Travel Motors		2 x axial-piston	
Parking Brake		Oil disc brake per motor	
Travel Speed (high/low)	km/h	4.4/2.5	
Gradeability	% (degree)	58 (30)	
Drawbar Pulling Force	kN	38.1	
<b>CRAWLER</b>			
Shoe	mm	Rubber	
Shoe Width	mm	300	
Ground Pressure	kPa	33.5	
<b>DOZER BLADE</b>			
Width x Height	mm	1,700 x 345	
Working Ranges (height/depth)	mm	395/320	
<b>SWING SYSTEM</b>			
Swing Motor		Axial piston motor	
Parking Brake		Oil disc brake, hydraulic operated automatically	
Swing Speed	min <sup>-1</sup>	8.4	
Tail Swing Radius	mm	850	
Min. Front Swing Radius	Over the front	mm	2,380
	At full boom swing	mm	1,980
<b>SIDE DIGGING MECHANISM</b>			
Type		Boom swing	
Offset Angle	to the left	degree	70
	to the right	degree	60

## WORKING RANGES

Unit: mm

MODEL	SK35SR
Arm length	1.37 m
a- Max. digging reach	5,350
b- Max. digging reach at ground level	5,200
c- Max. digging depth	3,050
d- Max. digging height	4,870
e- Max. dumping clearance	3,490
f- Min. dumping clearance	1,310
g- Max. vertical wall digging depth	2,470
h- Min. swing radius	2,320
i- Horizontal digging stroke at ground level	2,400
j- Dozer blade (height/depth)	395/320

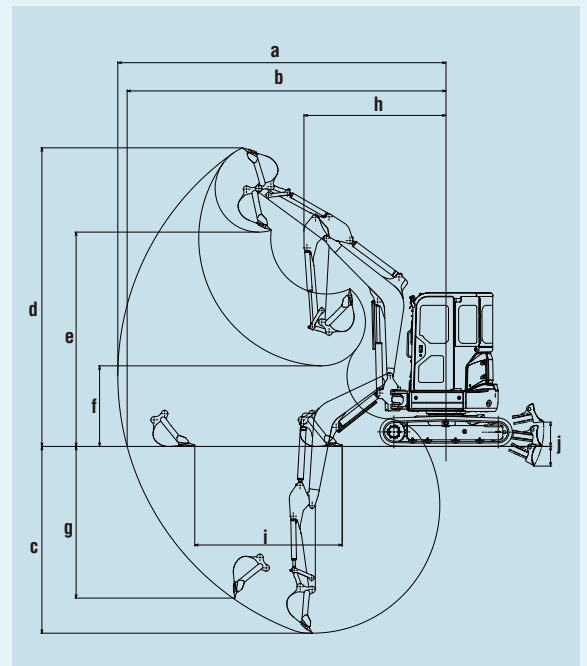

## GENERAL DIMENSIONS

Unit: mm

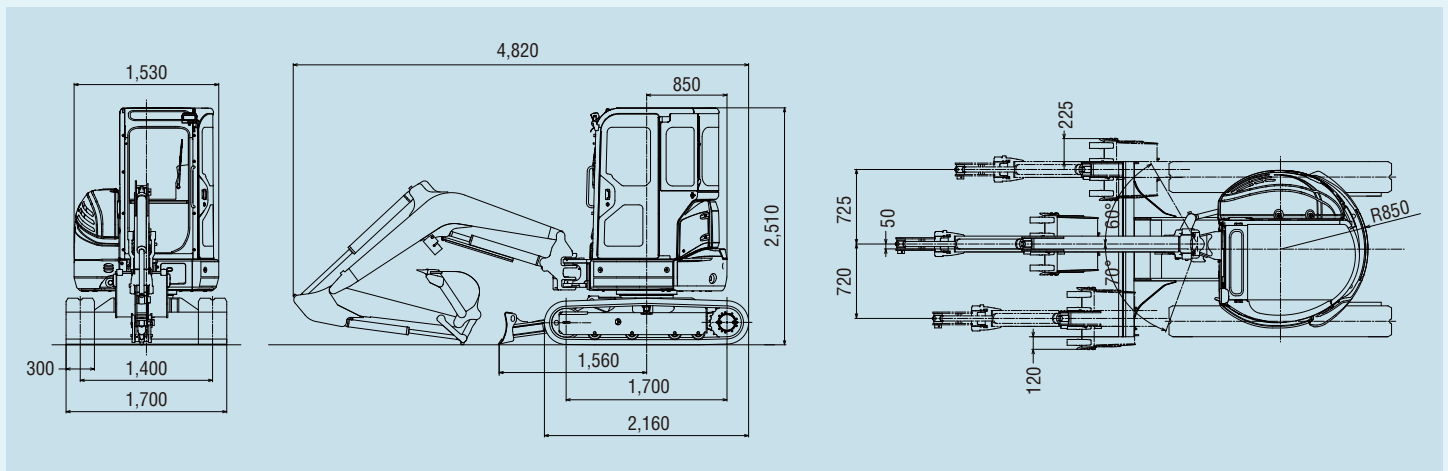

# LIFTING CAPACITIES

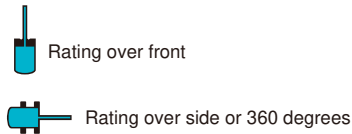
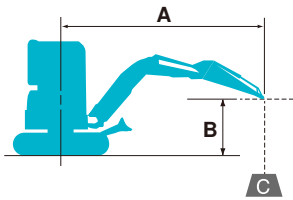

A: Reach from swing centerline to arm top  
B: Arm top height above/below ground  
C: Lifting capacities in kilograms  
Shoe: Rubber shoe Dozer blade: Up  
Relief valve setting: 23.0 MPa

SK35SR		Arm: 1.37 m, Bucket: Without Rubber Shoe: 300 mm										
		1.0 m		2.0 m		3.0 m		4.0 m		At Max. Reach		Max. Reach
B	A											
4.0 m	kg									800	750	3.32 m
3.0 m	kg							590	550	550	520	4.15 m
2.0 m	kg					900	840	570	540	470	440	4.54 m
1.0 m	kg					830	780	550	520	440	420	4.63 m
G. L.	kg			1,530	1,390	800	740	530	500	460	430	4.45 m
-1.0 m	kg	*2,290	*2,290	1,550	1,400	800	740			550	510	3.95 m
-2.0 m	kg			*1,550	1,460					880	820	2.90 m

- Notes:**
- Do not attempt to lift or hold any load that is greater than these lift capacities at their specified lift point radius and heights. Weight of all accessories must be deducted from the above lift capacities.
  - Lift capacities are based on machine standing on level, firm, and uniform ground. User must make allowance for job conditions such as soft or uneven ground, out of level conditions, side loads, sudden stopping of loads, hazardous conditions, experience of personnel, etc.
  - Arm top defined as lift point.
  - The above lifting capacities are in compliance with ISO 10567. They do not exceed 87% of hydraulic lifting capacity or 75% of tipping load. Lifting capacities marked with an asterisk (\*) are limited by hydraulic capacity rather than tipping load.
  - Operator should be fully acquainted with the Operator's and Maintenance Instructions before operating this machine. Rules for safe operation of equipment should be adhered to at all times.
  - Lift capacities apply to only machine as originally manufactured and normally equipped by KOBELCO CONSTRUCTION MACHINERY CO., LTD.

Note: This catalog may contain attachments and optional equipment that are not available in your area. And it may contain photographs of machines with specifications that differ from those of machines sold in your areas. Please consult your nearest KOBELCO distributor for those items you require. Due to our policy of continuous product improvements all designs and specifications are subject to change without advance notice. Copyright by **KOBELCO CONSTRUCTION MACHINERY CO., LTD.** No part of this catalog may be reproduced in any manner without notice.

## KOBELCO CONSTRUCTION MACHINERY U.S.A. INC.

4690 World Houston Parkway Houston, TX 77032  
<http://www.kobelco-usa.com/>

Inquiries To: