



For Earth, For Life
Kubota

SVL

KUBOTA COMPACT TRACK LOADER SVL75-2 / SVL95-2s

The outstanding power and exceptional comfort of Kubota's new Compact Track Loaders take high performance and productivity to a new level.



*This information is sourced from overseas and may not necessarily apply locally. It is essential that you confirm specifications and other information with your local Kubota dealer.

Need more productivity? Put the all-new Kubota Compact Track Loader to work for you.

Kubota, a trusted and world-leading manufacturer of construction equipment, is proud to introduce the all-new SVL75-2/SVL95-2s Compact Track Loaders. These new compact track loaders deliver best-in-class bucket breakout force and lifting capacity, outstanding stability, a wide and comfortable operator area, and much more. When it comes to high performance, reliability and comfort, the road leads to Kubota.

- **OUTSTANDING PERFORMANCE**
- **EXCEPTIONAL COMFORT**
- **EASY MAINTENANCE AND IMPRESSIVE DURABILITY**

SVL75-2

Engine gross horsepower (SAE J 1995): 74.3 HP (55.4 kW)

Rated operating capacity (35% of tipping load) : 1043 kg

Bucket breakout force : 2814 kg

Operating weight (Including operator weight 75 kg) : 4100 kg



COMPACT TRACK LOADER SVL75-2/SVL95-2s



SVL95-2s

Engine gross horsepower (SAE J 1995): 71.9 kW

Rated operating capacity (35% of tipping load) : 1451 kg

Bucket breakout force : 3611 kg

Operating weight (Including operator weight 75 kg) : 5125 kg



OUTSTANDING PERFORMANCE

Kubota engine

Common Rail System and Diesel Particulate Filter (DPF) Muffler

The Common Rail System (CRS) electronically controls the fuel injection timing and amount in stages rather than all at once for optimal combustion; resulting in greater efficiency, better fuel economy and less engine noise. The combination of Exhaust Gas Re-circulation (EGR) and Diesel Particulate Filter (DPF) reduces the emissions making the SVL Series engine Tier IV certified.

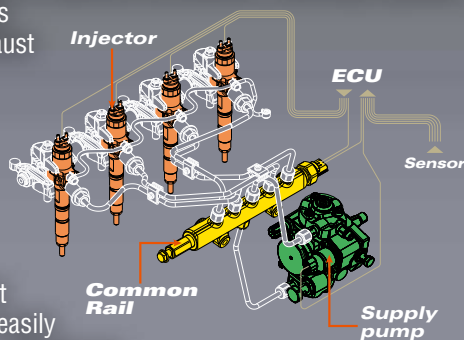

● Powerful Kubota engine

The powerful and reliable Kubota-built engine gets the job done quickly and easily with 74.3 hp* (SVL75-2) or 96.4 hp* (SVL95-2s).

* Engine HP Gross (SAE J 1995)

● SCR meter panel

An SCR system helps the SVL95-2s meet Final Tier4 requirements. A quick glance at the digital panel tells you how much Diesel Exhaust Fluid (DEF) remains in the tank and also when to refill it.





	SVL75-2	SVL95-2s
Bucket Breakout Force:	2814 kg	3611 kg
Arm Breakout Force:	2162 kg	3058 kg
Tipping Load:	2980 kg	4147 kg

● Automatic regeneration system

Kubota's original automatic regeneration system automatically burns accumulated particulate matter (soot) in the DPF muffler to keep the muffler clean for longer operation. For operational and safety reasons, automatic regeneration can be turned off with the inhibit switch when compact track loader is operating in areas that are near people, animals, and flammable materials.



● Electronic Travel Torque Management

Electronic Travel Torque Management System lets you work faster with more power. The ECU constantly monitors the load of the machine to optimally control hydraulic pump output according to the load, preventing engine stalls for smoother operation even under severe conditions.

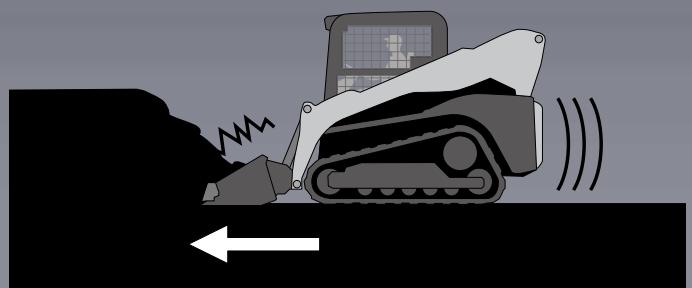

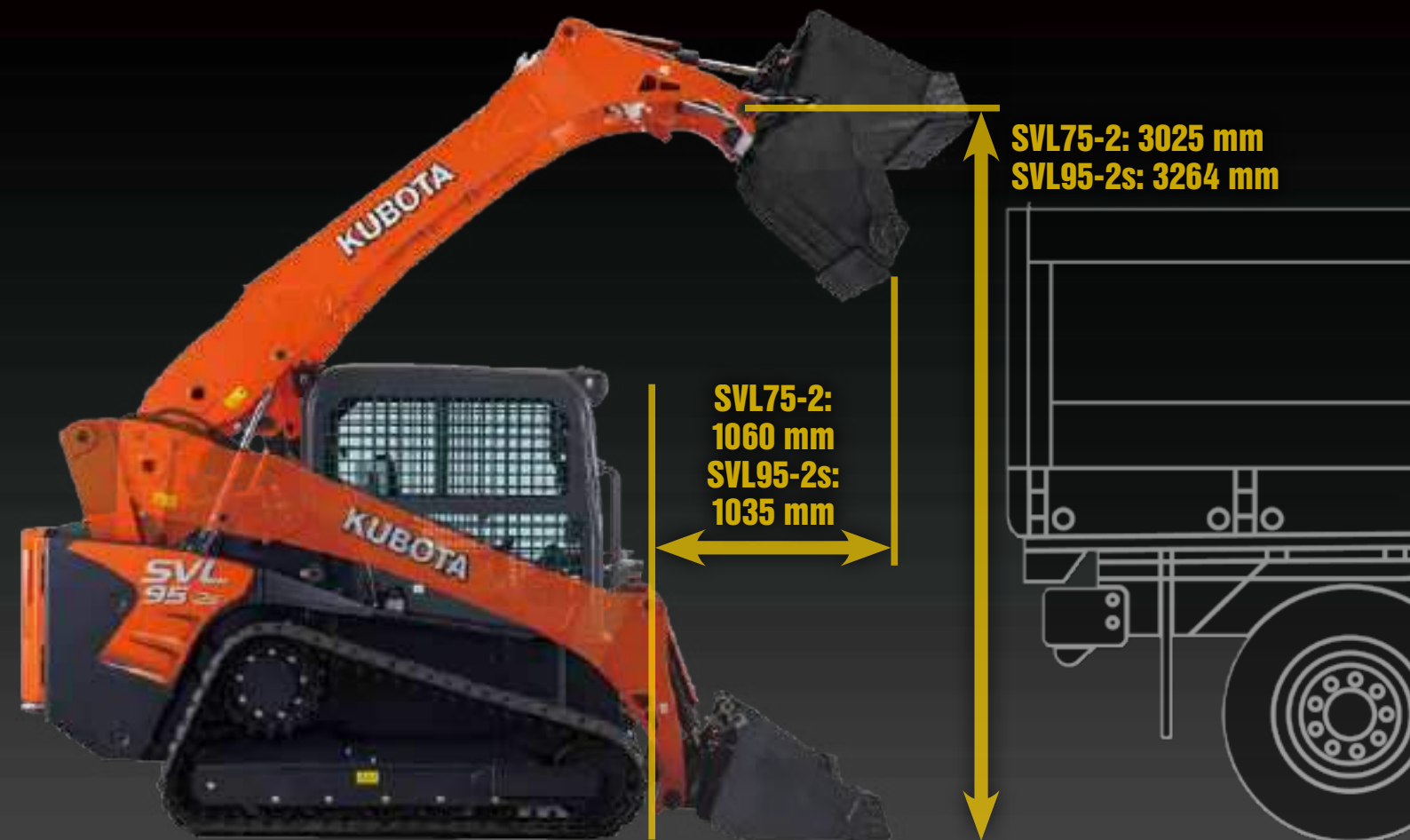

Kubota Unique Vertical Lift Design



- **Long Reach for Maximum Lifting and Dumping**
- **High Bucket Hinge Pin Height**

Kubota's unique vertical lift is designed to deliver an exceptionally long reach of 1060 mm (SVL75-2) and 1035 mm (SVL95-2s). In addition, the tip of the arm is optimally shaped for a tall hinge pin height of 3025 mm (SVL75-2) / 3264 mm (SVL95-2s) for easy dumping into trucks.



- **Standard Self-leveling Function**

This feature helps keep the bucket or fork in a horizontal position without the need to manually adjust the angle during lifting.

Travel Performance

Standard Two-speed Travel

Shift from low gear at 7.5 km/h (SVL75-2) / 8.0 km/h (SVL95-2s) to high gear at 11.5 km/h (SVL75-2) / 11.7 km/h (SVL95-2s) to get the job done faster.

Pilot Valve with Shuttle Piston

This ensures consistent oil flow which improves stability when going straight.

Higher Ground Clearance

A high ground clearance of 296 mm (SVL75-2) / 293 mm (SVL95-2s) lets you travel over large obstacles with ease.

Strong Traction Force

Kubota's original track lug design gives you more grip and a stronger traction force of 4390 kg (SVL75-2) / 5524 kg (SVL95-2s).

Excellent versatility

● Multi-function Levers

The multi-function levers provide fingertip control of all major vehicle and attachment operations, letting you keep both hands on the levers at all times for optimal operating efficiency.

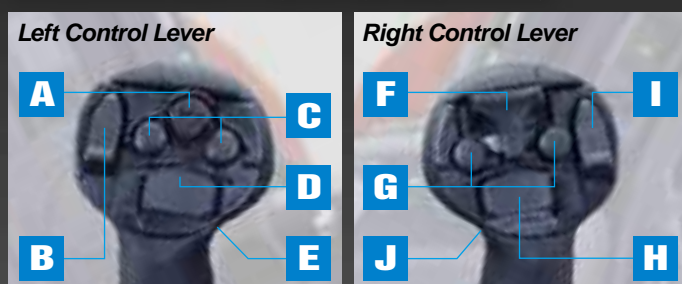

- A. Horn
- B. -Not used-
- C. AUX1
- D. AUX3 or Turn Signal
- E. Travel Speed

- F. Proportional AUX Switch
- G. AUX Hold Switch
- H. AUX2
- I. AUX Mode Change
- J. Float Switch

● High-flow Hydraulics

Having high flow increases the hydraulic muscle for attachments that need more hydraulic horsepower. With this option auxiliary hydraulic flow increases to 110.9 l/min (SVL75-2) / 152 l/min (SVL95-2s). The coupler manifold includes both 1/2" and 3/4" couplers.

Aux. hydraulic flow		
SVL75-2	Std.	66 l/min
	High	110.9 l/min
SVL95-2s	High	152 l/min



Powerful hydraulic system

● Load Sensing System (SVL95-2s)

● Enhanced Control Valve System (SVL95-2s)

The SVL95-2s features a new Load Sensing System and improved control valve to provide even more powerful pushing and driving forces, even for combined attachment operations. Plenty of power to travel on slopes and handle attachment work also means you'll get the job done faster.

● Adjustable Maximum Oil Flow Control (Option) (SVL95-2s)

Quick and easy 5 modes of the AUX flow ensures the optimal flow rate for every job you do. Adjustable Maximum Oil Flow Control is available only for high flow.



EXCEPTIONAL COMFORT

Comfortable Cab

● Wider Cab Entrance

A wider entrance makes it easier to get in and out.

● Wide And Clean Cab

The spacious interior minimizes fatigue even during long work hours.

● High-back Full Suspension Seat

The standard suspension seat offers outstanding comfort. (Air Suspension seat is optional)

● Arm Rest

The spacious cab also includes ergonomically placed arm rests on the right and left sides of the seat to minimize operator fatigue. The arm rests have been designed to increase operator space.

● Wide Leg Room

The cab provides ample leg room to reduce operator fatigue.

● Ready for radio installation (Option)

The SVL-series Factory Closed cab now comes prewired with speakers already installed, all that needs to be added is the radio.

● Easy-clean Floor Mat and Drain Outlet

The soft rubber floor mat is easy to remove and clean. And with the built-in drain outlet, the mat can be washed in the cab.



Excellent 360° Visibility

The edge of the bucket can be seen from the seat. Improved visibility translates to better safety on the job.



● Hand/Dial and Foot Throttle

The SVL95-2s' dial and foot throttle, and the SVL75-2's hand and foot throttle both allow you to match the engine speed to the task. The hand/dial throttle is ideal for jobs requiring constant engine speed such as cold planing, trenching or snow blowing. The foot throttle lets the operator vary engine speed for other applications.



(SVL75-2)



(SVL95-2s)



(SVL75-2/SVL95-2s)

EXCEPTIONAL COMFORT

Pressurized Cab

The cab is pressurized to keep dust, flying debris, and insects away to enhance comfort on the job. Furthermore, noise is kept down to let you work for long hours with minimal fatigue.



Excellent Air Conditioning Performance

● Optimized Air Conditioning

Thanks to improved vents, the climate control system provides an optimized airflow for outstanding cooling and heating performance—and supreme operator comfort—all year round.

● Enhanced Defrosting and Demisting Functions

Ample airflow prevents the windows from fogging up or freezing during the cold months of the year.



CAB

Easy-open Sliding Windows

The sliding front door can be opened regardless of the position of bucket or attachment; allowing you to get in or out in difficult situations and also work with the front door open. It is an added benefit when hooking up attachments, improving the visibility and safety.

The sliding side windows are split in the middle and can be opened separately from the front or rear.



EASY MAINTENANCE IMPRESSIONS

Easy Maintenance

● Routine Checks

Simply open the rear bonnet to access all components for daily routine inspections.

● Slide-and-tilt Radiator and Oil Cooler

The radiator can be tilted for easy cleaning.

● DEF easy refill access (SVL95-2s)



● Tilt-up Cab

The cab can be tilted 72° without having to lift the arm, allowing easy access to the hydraulic pumps, valves, lines and hydraulic tank.



● Large Space for Tool Box

The SVL75-2 offers a convenient and large tool box for storing a grease gun and other necessities.



ANCE & DURABILITY

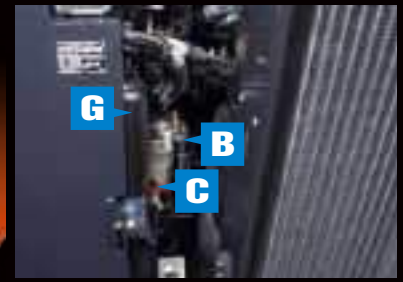

- A. Dual Element Air Cleaner**
- B. Fuel Filter**
- C. Water Separator**
- D. Maintenance-Free Battery**
- E. Coolant**
- F. Slide-and-tilt Radiator**
- G. DEF Tank**

Diesel Particulate Filter (DPF) and Selective Catalytic Reduction (SCR)

The Diesel Particulate Filter and Selective Catalytic Reduction meet the latest Tier4 diesel emissions regulation by collecting particulate matter (PM) and NOx from exhaust gas for cleaner exhaust emissions.



Impressive Durability

1. Welded, Integrated Mainframe and Undercarriage

The undercarriage forms an integral part of the main frame for maximum durability.

2. Kubota Original Rubber Tracks

Kubota's original rubber tracks offer outstanding durability and long-life performance. Furthermore, Kubota's original lug pattern prevents soil from accumulating and improves traction force. 380 mm wide tracks are optional for the SVL75-2.

3. Triple Flange Lower Track Rollers

A highly reliable triple flange design not only minimizes the risk of detracking, but improves stability as well. They are lifetime sealed and lubricated.



EQUIPMENT

STANDARD EQUIPMENT

- Open CAB (ROPS / FOPS Level 1)
- Top / Rear window
- Suspension seat
- 2" Retractable seat belt
- Operator presence control
- Pull down arm rest
- Hand/Dial and Foot throttle
- 12V electric outlet
- Horn
- Radio Ready
- Lockable fuel cap
- Backup alarm
- Working lights (Front 2 / Rear 2)
- Glow plug
- High-flow hydraulics (1/2" and 3/4" couplers for SVL95-2s)
- Hydraulic quick coupler
- Loader arm float function
- Bucket self-leveling (up only)
- Wet disc parking brakes
- Two-speed travel
- Rubber crawler SVL75-2-12.6" (320mm) SVL95-2s-17.7" (450mm)

OPTIONAL EQUIPMENT

- High-flow hydraulics (1/2" and 3/4" couplers for SVL75-2)
- Adjustable maximum oil flow
- 14-pin coupler for attachments
- Wide rubber crawler SVL75-2-15" (380mm)
- Rear bonnet lock Kit
- Rear view mirror
- Radiator screen
- ...and much more.



SPECIFICATIONS

Model		SVL75-2	SVL95-2s		
Type of operator station		Open CAB / Closed CAB	Open CAB / Closed CAB		
Engine	Model	V3307-CR-TE4	V3800-TIEF4		
	Emission certification	Tier 4	Tier 4		
	Gross HP (SAE J1995)	HP (kW)/rpm	74.3 (55.4)/2400	96.4 (71.9)/2400	
	Net HP (SAE J1349)	HP (kW)/rpm	68.8 (51.3)/2400	87.0 (64.9)/2400	
	Displacement	cc	3331	3769	
	Cylinders		4	4	
	Bore × Stroke	mm	94 × 120	100 × 120	
Aspiration		Turbocharged	Turbocharged		
Loader Performance	Rated operating capacity-35% tipping load	kg	1043	1451	
	Rated operating capacity-50% tipping load	kg	1490	2074	
	Tipping load	kg	2980	4147	
	Breakout force	Bucket	kg	2814	3611
		Lift arm	kg	2162	3058
Lift arm path		Vertical	Vertical		
Undercarriage	Track Width	Standard	mm	320	450
		Wide	mm	380	N/A
	Ground pressure	Standard	psi	5.6 / 5.8	4.4 / 4.5
		Wide	psi	4.7 / 4.9	N/A
	Track rollers (per side)			4	5
	Track ground contact length	mm	1436	1667	
	Travel speed	Low	km/h	7.5	8.0
		High	km/h	11.5	11.7
Traction force	kg	4390	5524		
Min. ground clearance	mm	296	293		
Hydraulic system	Aux. hydraulic flow	Std./High	ℓ/min.	66.0 / 110.9	N/A / 152
	Aux. hydraulic pressure		kgf/cm ²	224.0	249.8
Service refill capacities	Hydraulic system	ℓ	60	68	
	Hydraulic tank	ℓ	35	38.1	
	Fuel tank	ℓ	93	109	
	DEF tank	ℓ	N/A	18.8	
Operating weight (Includes operator weight 75 kg)		kg	4100 / 4225	5125 / 5250	

The company reserves the right to change the above specifications without notice. This brochure is for descriptive purposes only. Please contact your local Kubota dealer for warranty information. For your safety, Kubota strongly recommends the use of a Rollover Protective Structure (ROPS) and seat belt in almost all applications.

DIMENSIONS

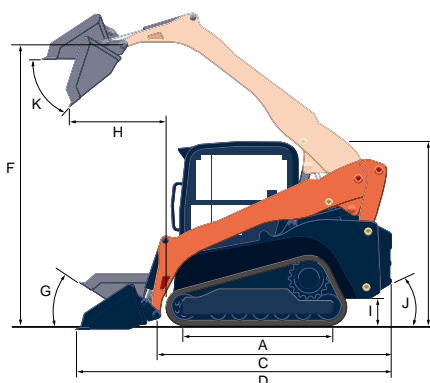
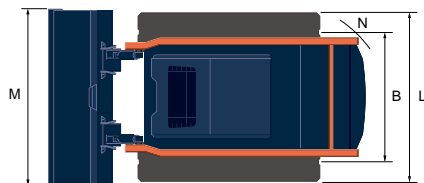

Model	SVL75-2	SVL95-2s		
A Length of track on ground	mm	1436	1667	
B Track gauge	mm	1355	1512	
C Length w/o bucket	mm	2768	3137	
D Length w/bucket on ground	mm	3576	3929	
E Height to top of cab	mm	2083	2116	
F Bucket hinge pin height at max. lift	mm	3025	3264	
G Rollback angle at carry position	degree	27	27	
H Reach at max. lift and dump	mm	1060	1035	
I Ground clearance	mm	296	293	
J Departure angle	degree	31.5	31	
K Max. dump angle	degree	40	43	
L Vehicle width	Standard track / Wide track	mm	1675 / 1735	1962
M Width with bucket	mm	1727	2032	
N Turning radius from center-machine rear	mm	2720	3220	



KX033-4

From our excavators, skid steers and wheel loaders to our tractor/loader/backhoes, Kubota offers a wide range of reliable, high-performance construction equipment to get the job done right.



R065



SSV65/SSV75

©2017 Kubota Corporation



KUBOTA Australia Pty Ltd

25-29 Permas Way, TRUGANINA Vic, 3029
Freecall: 1800-334-653
Email: sales@kubota.com.au

Web Site: <http://www.kubota.com.au>

Kubota New Zealand Limited

Freecall: 0800-582-682
Email: sales@kubota.com.au

Web Site: <http://www.kubota.co.nz>